

INSTRUCTION MANUAL

Locations of Control

Main Unit

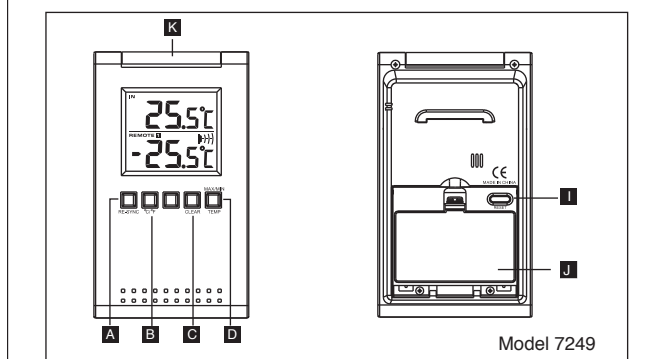
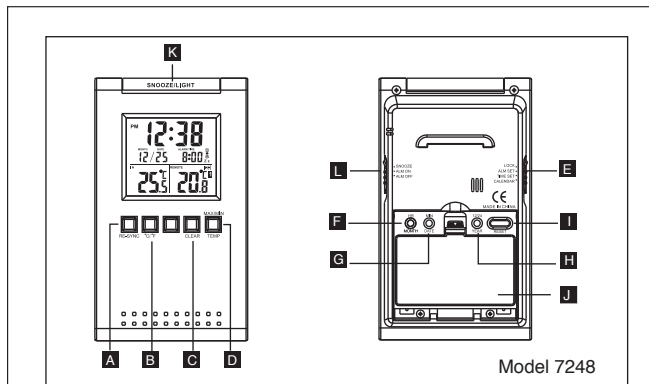

- | | |
|---|---|
| A RE-SYNC BUTTON | G MIN/DATE BUTTON |
| B °C/°F BUTTON | H 12/24/YEAR BUTTON |
| C CLEAR BUTTON | I RESET BUTTON |
| D TEMP/MIN/MAX BUTTON | J BATTERY DOOR |
| E LOCK/ALARM SET/TIMESET/CALENDAR SWITCH | K SNOOZE/LIGHT BUTTON |
| F HR/MONTH BUTTON | L SNOOZE/ALARM ON/ALARM OFF SWITCH |

Remote Unit (Transmitter)

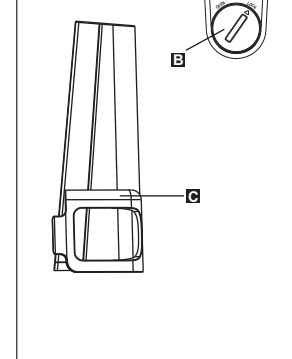
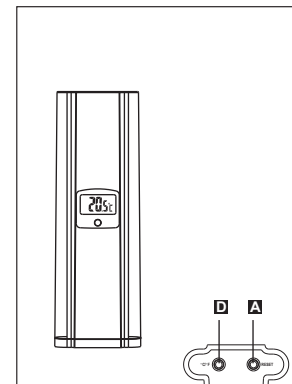

- | |
|------------------------------|
| A RESET Button |
| B Battery Compartment |
| C Wall Bracket |
| D °C/°F |

Model 7060

☞The configuration of your clock may differ somewhat from that shown in the illustration.
☞AA" or "AAA" size battery. This clock may use more than one piece of battery. Please refer to the
☞engraved battery marks inside the battery compartment for the correct battery type.

Feature

- ☑IN temperature and REMOTE temperature
- ☑Centigrade or Fahrenheit readout
- ☑Hour and minute display
- ☑12 or 24 hour format
- ☑Calendar from July 1, 1997 to December 31, 2039
- ☑Maximum and Minimum Temperature record
- ☑Battery life : approximate 1 year
- ☑Operating temperature from 0°C to 50°C (32°F to 122°F)
- ☑Temperature measuring range from -50°C to 70°C (-58°F to 158°F)
- ☑Temperature resolution 0.1°C

Before You Begin

To ensure proper functioning of the RF Thermo Clock, please follow this set up procedure.

- ☑Insert batteries for main unit (Refer to instructions for battery installation).
 - ☑Place the main unit as close as possible next to the remote unit and insert ☐ ☐ batteries for the remote unit.
 - ☑Position the remote unit and main unit within effective transmission range, which ☐ ☐ in usual circumstances is 20 to 30 meters.
- Note that : 1) Two main units (RF Thermo Clock and RF Thermo) are in the pack, ☐ ☐ ☐ alarm clock and backlight function are only available for RF thermo ☐ ☐ ☐ ☐ clock.
- 2)The effective range is affected by the building materials and where ☐ ☐ ☐ ☐ the main and remote unit are positioned. Try various setup for the ☐ ☐ ☐ ☐ best results.

Batteries Installation

Batteries installation of main unit

- ☑Open the battery cover of the main unit.
- ☑Insert 2 pcs of AA size batteries in proper polarity (+) and (-) as indicated.
- ☑Close the battery cover.

Batteries installation of remote unit

- ☑Open the battery compartment door.
- ☑Insert 2 pcs of AA size batteries in proper polarity (+) and (-) as indicated.
- ☑Close the battery cover.

Notes: Do not use old batteries or different batteries together.

Getting Started

Once batteries are placed in the main unit, it will start receive signal for 5 minutes, also once batteries are placed in the remote unit, it will start to transmit information at 3 minutes intervals. Upon successful reception, the remote unit temperature will be displayed on the Remote temperature field. The main unit will automatically update the remote reading at 3 minutes intervals.

If no signals are received within 5 minutes intervals, blank "- -" will be displayed.

Check IN / REMOTE Temperature

The indoor temperature is displayed on the IN temperature field and the remote temperature will be displayed on the REMOTE temperature field.

If no reading are received for five consecutive times, blank "- -" will be displayed on REMOTE field. In this case, pressing of RE-SYNC button will force the main unit to receive signals for 6 minutes (Refer to Lose Sync.)

Maximum and Minimum In/Remote Temperature

The maximum and minimum recorded temperature readings will automatically be stored in the memory.

To display the maximum and minimum temperature, press TEMP MAX/MIN once to display the IN maximum and minimum temperature and again the REMOTE maximum and minimum temperature. The respective indicators, IN and REMOTE will be displayed.

To clear the memory, press CLEAR when the maximum and minimum temperature records are shown, it will clear the record of the shown temperature field.

Clock Set

At the back of the RF Thermo Clock, slide the switch to TIME SET and the time will keep flashing on the display. Then press HR or MIN button to set your desired time and slide the switch to the LOCK position to complete the time set.

Alarm Set

At the back of the RF Thermo Clock, slide the switch to ALM SET and the alarm time will keep flashing on the display. Then press HR or MIN button to set your desired alarm time. Slide to ALM ON position, the sign  will appear on the display, the alarm function is activated. Slide to SNOOZE position to activate the Snooze Alarm, the Zz sign will appear on the display to indicate the activation of the SNOOZE function. Once the alarm starts to ring, you can activate the snooze by pressing the SNOOZE/LIGHT button. The alarm will stop for 5 minutes and it will start to ring again. Slide to ALM OFF to completely stop the alarm. Alarm Duration: 1 minute

Calendar Set

At the back of the RF Thermo Clock, slide the switch to CALENDAR and the date will keep flashing on the display. Then press MONTH, DATE and YEAR button to set your desired calendar setting and slide the switch to the LOCK position to complete the calendar set.

12HR/24HR International Time Display Set



Press the 12HR/24HR button to choose the desired display format. "PM" will be displayed only in 12HR format.

Centigrade (°C) or Fahrenheit (°F) set

Press the °C/°F button to choose the Centigrade or Fahrenheit readout. Note that the remote temperature display on the main unit is dominated by the selection on the main unit. Whatever the display unit of the remote unit is, it will be automatically converted to the chosen one of the main unit.

Receiver stage indicator

The stage indicators indicate the following stage of the received signal.

	NO SIGNAL DETECTION
	SIGNAL DETECTION
	SUCCESSFUL RECEPTION

Lose Sync

If without obvious reasons the display goes blank, press RE-SYNC to force the receiver to start receive signal. If it still fails, check:

- ☑The remote unit is still in place.
- ☑The batteries of both remote unit and main unit, replace as necessary.
- ☑The transmission is within range and path is clear of obstacles and interference. Shorten the distance when necessary.

Interference

Signals from other household devices, such as entry controls, door bells and home security systems, may interfere the RF Thermo Clock to cause temporarily reception failure. This is normal and does not affect the general performance of the product. The transmission and reception of temperature reading will resume once the interference stopped.

Using the Stand

The main unit has a built in stand which can flipped open, it can support the main unit on a flat surface. Also, you can drive the screws to fix the wall mount holder to the wall and locate the main unit on it.

1) Pull down flip overstand to access battery compartment

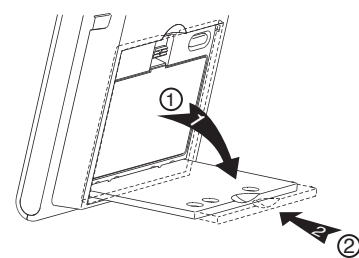

2) Insert stand into the back case

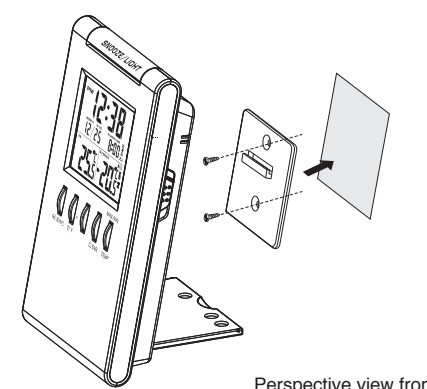

Perspective view from front and right side

The remote unit comes with a wall mount holder which can hold the unit on wall, or just place it on a flat surface.

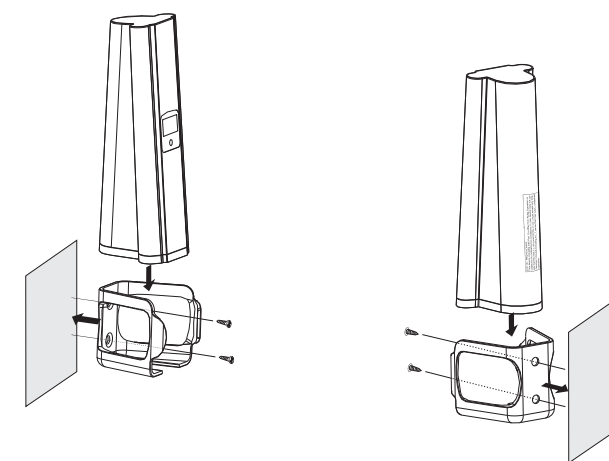

Reset the RF Thermo Clock

Press the RESET button when the RF Thermo Clock does not operate normally. Note: Once resetting the RF Thermo Clock, the main unit will start to receive for 5 minutes (Refer to Getting Started).

Take care of your RF Thermo Clock

- ☑Avoid exposing your RF Thermo Clock to extreme temperatures, water or ☐ ☐ ☐ severe shock.
- ☑Do not put your RF Thermo Clock in conditions of excessive force, shock, dust, ☐ ☐ extreme temperature or humidity. Any of these conditions may shorten the life of ☐ ☐ the clock.
- ☑Do not tamper with any of the internal component of the RF Thermo Clock. This ☐ ☐ will invalidate the warranty under the above condition.
- ☑Use only fresh batteries. Mixing old and new batteries may cause battery ☐ ☐ ☐ leakage.

Specification

General :

- RF transmission frequency☐ :☐ 433.92MHz
- RF transmission range☐ :☐ up to 30 meters

Main Unit :

- Display temperature range☐ :☐ -50.0°C to 70.0°C
- ☐ ☐ (-58.0°F to 158.0°F)
- Proposed operating range☐ :☐ 0.0°C to 50.0°C
- ☐ ☐ (32.0°F to 122.0°F)
- Temperature resolution☐ :☐ 0.1°C
- Power☐ :☐ 2 pcs AA 1.5V battery
- Dimension☐ :☐ 120 x 22 x 70mm

Remote Unit :

- Display temperature range☐ :☐ -50.0°C to 70.0°C
- ☐ ☐ (-58.0°F to 158.0°F)
- Proposed operating range☐ :☐ -20.0°C to 60.0°C
- ☐ ☐ (-4.0°F to 140.0°F)
- Temperature resolution:☐ ☐ 0.1°C
- Power☐ :☐ 2 pcs AA 1.5V battery
- Dimension☐ :☐ 125 x 40 x 45mm

Warning: Changes or modifications to this unit not expressly approved by the party responsible for compliance could void the user's authority to operate the equipment.

Note: This equipment has been tested and found to comply with the limits for a Class B digital device, pursuant to Part 15 of the FCC Rules. These limits are designed to provide reasonable protection against harmful interference in a residential installation. This equipment generates, uses and can radiate radio frequency energy and, if not installed and used in accordance with the instructions, may cause harmful interference to radio communications.

However, there is no guarantee that interference will not occur in a particular installation. If this equipment does cause harmful interference to radio or television reception, which can be determined by turning the equipment off and on, the user is encouraged to try to correct the interference by one of more of the following measures:

- ☑Reorient or relocate the receiving antenna.
- ☑Increase the separation between the equipment and receiver.
- ☑Connect the equipment into an outlet on a circuit different from that to which the ☐ ☐ receiver is connected.
- ☑Consult the dealer or an experienced radio/TV technician for help.

Under the environment with radio frequency interference, the sample may malfunction and require user to reset the sample.